



Purestream™
Ballast Water Management System
Innovative UV Disinfection Technology



Purestream™ UV Ballast Water Management System

A new advanced UV ballast water management technology that provides effective treatment and unique operational advantages for vessels.



The Purestream™ ballast water management system, developed to meet the IMO D-2 and the USCG Ballast Water Discharge standards, combines Atlantium's proven UV solution with filtration, enabling the maximum flexibility to ship owners, while assuring compliance with the strictest inspection process by port authorities.

Purestream™ Science of Compliance

The Purestream system is a non-chemical, environmentally friendly solution based on a revolutionary 20-micron screen filter and a medium pressure UV system. Atlantium's strong technical knowledge for overcoming the worst water condition and resistivity of target organisms were the basis of the UV system design.

The UV system uses proprietary comprehensive real-time monitoring of critical parameters to automatically and efficiently maintain the minimum UV dose required to meet application-specific needs. Purestream also features an extensive control mechanism that assures operators and authorities about the unit's functionality.

UV Dose = UVT + Flow + Power + UV Apparatus

Purestream automatically and efficiently maintains the UV dose required to meet IMO and USGC Type Approval.

Purestream continuously monitors UVT and adjusts the UV dose accordingly to remain in IMO and USCG regulatory compliance. Purestream is designed for $UVT \geq 40\%UVT$.

Purestream continuously controls the flow to provide the validated UV dose.

Purestream continuously monitors the UV output of each UV lamp (radiation intensity) with a dedicated sensor, one per lamp.

Designed by Atlantium to deliver the needed dose in the most efficient way under the most challenging water conditions.

Ballasting Process

During ballasting, the water flows through a 20-micron screen filter to remove organisms and particles. The filter features an enhanced backwash and self-cleaning mechanism for ease of operation and use. The ballast water then flows through the Purestream UV system to kill and inactivate organisms and bacteria and meet IMO and USCG Type Approval.

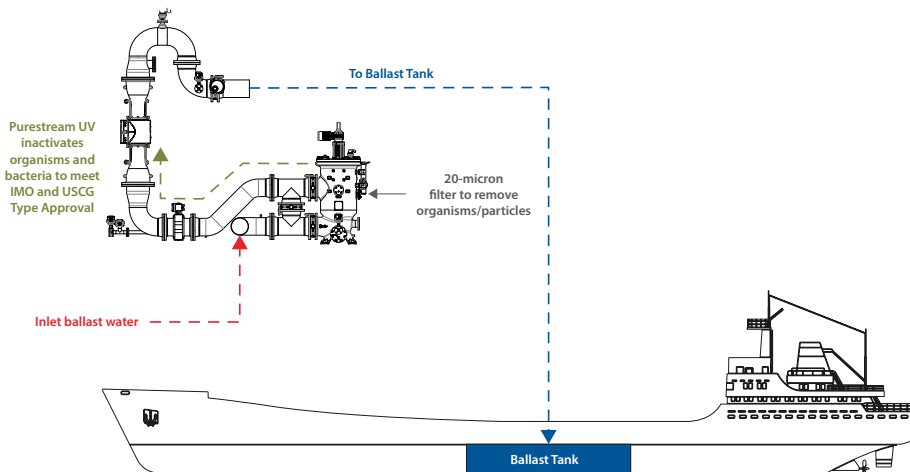

Purestream™ One-Pass™ Mode (IMO)

Water treatment only during ballasting
No need for water treatment during de-ballasting

Purestream™ Go™ (USCG)

No holding time required before de-ballasting,
an advantage for vessels with frequent port
calls/ballast operations

Purestream™ One-Pass™

For the IMO, the Purestream technology has demonstrated a mode of operation that enables one-pass treatment (Purestream™ One-Pass™). As a result, operation of the Purestream system is only required during ballasting and there are no requirements for water treatment during de-ballasting. This unique attribute reduces the overall power consumption by 50% when compared to traditional UV systems while doubling the unit's reliability.

De-Ballasting Process

During de-ballasting, the filter is automatically bypassed and ballast water flows through the Purestream system for a second-pass treatment before discharge. With Purestream™ Go™ there are no holding time limitations for de-ballasting. For the IMO, Purestream™ One-Pass™ mode processing is used for de-ballasting.

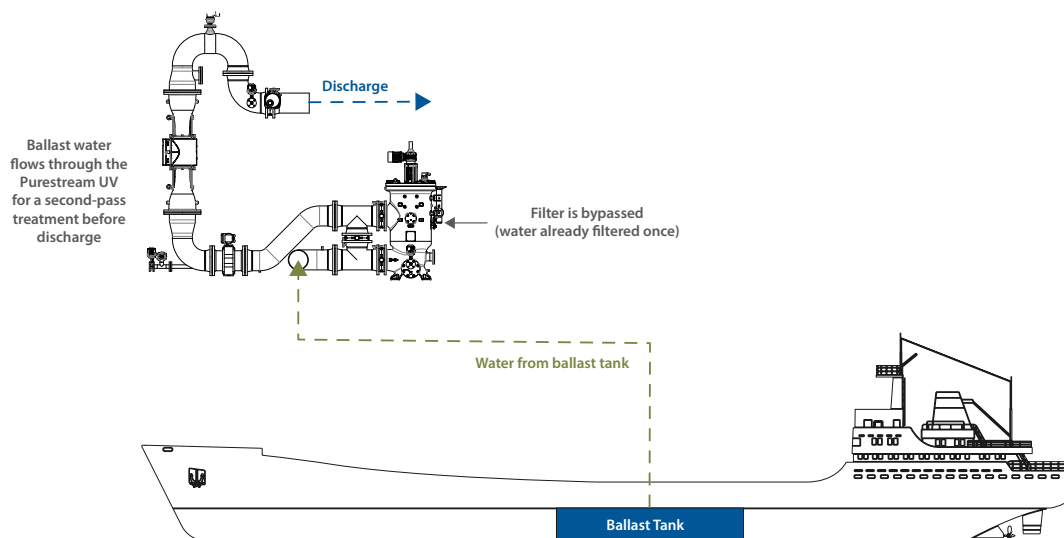

Purestream system is validated to operate at **minimum retention times** (≤ 24 hours) following treatment under difficult water conditions with UV transmittance as low as **40% UVT**.

Purestream™ Solution

Purestream ballast water management systems are designed to treat 100 – 1,500 m³/h of fresh, brackish, or seawater. Purestream is delivered as loose modules to ensure flexibility and ease of installation in space-constrained engine rooms. Alternatively, a container-based deckhouse solution (skid arrangement) is available.

Zone 1 approval is underway.

Purestream™ Features and Benefits

- Real-time dose monitoring and advanced control system enables treatment of maximum flow at lowest UVT levels
- Suitable for treatment on all water types and temperatures, no salinity or heating requirements
- One pass treatment (IMO)
- 24-hour retention time validation, (USCG) (0-hour-in process)
- Flexible installation, loose modules or skid systems
- Small footprint for filter, UV and CIP skid
- No hazardous chemical handling or byproducts

Purestream™ Shipboard Installation

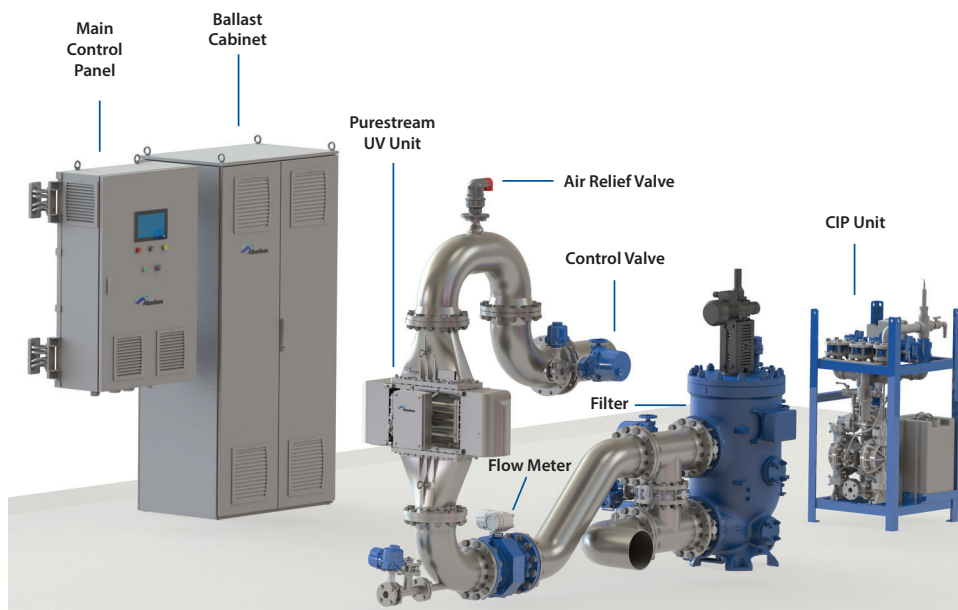

Purestream™ Process Control Operator Interface

The Purestream system features a proprietary and intuitive operator-friendly interface for continuous and extremely accurate real-time automated control and monitoring that ensures full regulatory compliance. The process control is fully automated, with clear visual controls provided.

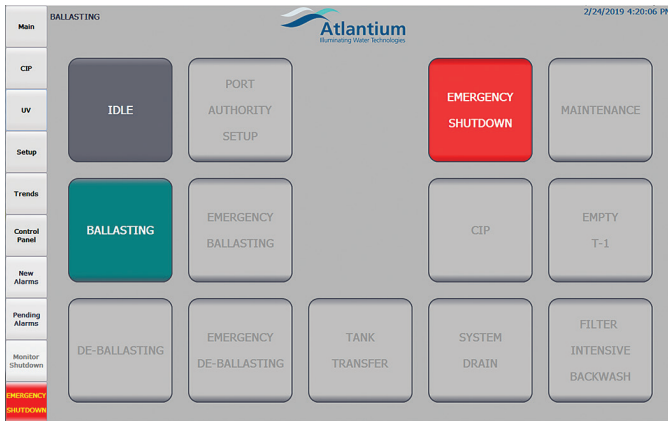

Purestream's **innovative dose-control** lets you know the required ballasting time in advance while automatically maintaining the **process 'On-spec'** at all times.

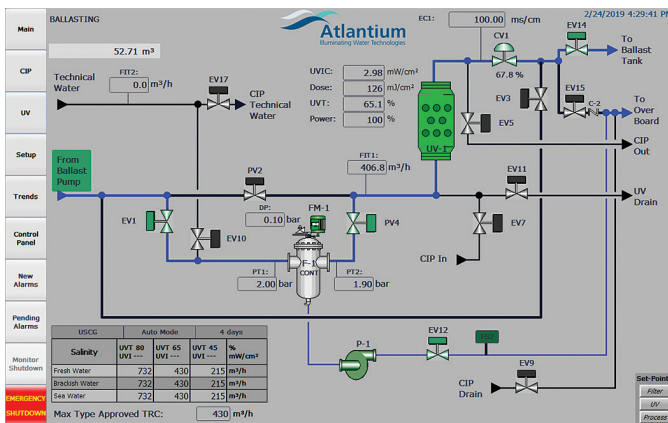

Operators select the Authority (IMO or USCG) for intended location of de-ballasting and the holding time. Then the ballasting or de-ballasting process is selected. The One-Pass™ ballasting mode can also be selected at this time if desired.

Global Presence — Distribution / Service / Support

Atlantium's UV technology has been proven since 2003. As a leading non-chemical AIS solutions provider with more than 15 years of experience, Atlantium's technology has been provided to 3,000+ installations globally.



Atlantium Marine, a part of Atlantium Technologies, is a global leader in UV treatment solutions for marine and ballast water applications.

The Purestream™ UV ballast water management system is a proven and effective alternative to chemical-based treatment technologies for the treatment of regulated organisms. Purestream systems are globally supported and spare parts such as UV lamps and filter elements are readily available.



Atlantium Technologies

www.atlantium.com
purestream@atlantium.com info@atlantium.com

For more information, contact your Atlantium representative
© 2020 Atlantium Technologies. All rights reserved. 12/20